



# User Instruction Manual

## M2(R) PRECHARGED PNEUMATIC AIR RIFLES

**Maximum Fill pressure: 300 bar (approximately 4,350 psi)**

**BRAND:** Ataman  
**DESCRIPTION:** PCP Airgun

**READ ALL INSTRUCTIONS AND WARNINGS IN THIS MANUAL BEFORE USING THIS AIRGUN.  
THIS INFORMATION COULD SAVE YOUR LIFE AND THE LIVES OF OTHERS.**

**! WARNING:** NOT A TOY. ADULT SUPERVISION REQUIRED. MISUSE OR CARELESS USE MAY CAUSE SERIOUS INJURY OR DEATH. MAY BE DANGEROUS UP TO 1000 YARDS (915 METERS).

**THIS IS A HIGH POWERED AIRGUN INTENDED FOR USE BY THOSE 18 YEARS OF AGE OR OLDER.**  
READ ALL INSTRUCTIONS BEFORE USING. BUYER AND USER HAVE THE DUTY TO OBEY ALL LAWS ABOUT THE USE AND OWNERSHIP OF THIS AIRGUN.

**! WARNING:** DO NOT BRANDISH OR DISPLAY THIS AIRGUN IN PUBLIC; IT MAY CONFUSE PEOPLE AND MAY BE A CRIME. POLICE AND OTHERS MAY THINK IT IS A FIREARM. DO NOT CHANGE THE COLORATION OR MARKINGS TO MAKE IT LOOK MORE LIKE A FIREARM. THAT IS DANGEROUS AND MAY BE A CRIME.

**CAUTION:** YOU AND OTHERS WITH YOU SHOULD ALWAYS WEAR SHOOTING GLASSES TO PROTECT YOUR EYES.

**CAUTION:** ALWAYS USE THE CORRECT CALIBER AMMUNITION THAT IS SUITABLE FOR THE AIRGUN. USE ONLY AMMUNITION DESIGNED FOR THIS AIRGUN.

Congratulations on your purchase of the **Ataman Precharged Pneumatic Air Rifle**. Please read this instruction manual completely. Always carefully follow the safety instructions found in this manual and keep this manual in a safe place for future use.

CONTENTS
1. Rules of Safe Shooting
2. Learning the Parts of the PCP Airgun
3. Operating the Safety
4. Fill/Charge Airgun with Hand Pump
5. Fill/Charge Airgun with High Pressure Charging Tank
6. Uncocking
7. Loading the Magazine
8. Installing the Magazine
9. Firing the Air Rifle
10. Trigger Adjustments
11. Cleaning the Barrel
12. Operation of Adjustable Stock
13. Storage of the Airgun
14. Troubleshooting
15. Specifications
16. Warranty
17. Customer Service
18. Company Contact Information

# 1. Rules of Safe Shooting

- **NEVER** point the airgun at any person.
- **NEVER** point the airgun at anything you do not intend to shoot.
- **ALWAYS** treat the airgun as if it was loaded and handle it with the same respect you would a firearm.
- **ALWAYS** aim in a SAFE DIRECTION. **ALWAYS** keep the muzzle pointed in a SAFE DIRECTION.
- **NEVER** put any part of your hand over the muzzle.
- **ALWAYS** keep the airgun **ON “SAFE”** until you are ready to shoot in a SAFE DIRECTION.
- Check behind and beyond your target to be certain you have a safe backstop and that no person or property can be endangered.
- Place the backstop in a location that will be safe should the backstop fail.
- Replace the backstop if it becomes worn.
- **ALWAYS** be sure of your target and what lies beyond it in case you miss.
- **NEVER** shoot at hard surfaces, water or anything else that may cause a ricochet.
- This airgun may only be used where your local laws permit or at shooting ranges allowed by the law, and only if the ammunition does not travel further than the shooting area. Keep in mind the maximum range of the ammunition. **ALWAYS** abide by laws and regulations that apply to airguns.
- **ALWAYS** check to see if the airgun is ON “SAFE” and unloaded when getting it from another person or from storage.
- **ALWAYS** keep your finger off the trigger and away from the trigger guard until ready to shoot.
- You and others with you should **ALWAYS** wear safety shooting glasses to protect your eyes.
- If your reading or prescription glasses are not certified safety glasses, make sure you wear shooting glasses over your regular glasses.
- The shooter and everyone in the vicinity should wear hearing protection when shooting **and** filling guns with high-pressure air.
- **NEVER** load your gun until you’re ready to shoot and it’s safe to do so.
- **ALWAYS** use the correct caliber ammunition that is suitable for the airgun. Use **ONLY** ammunition designed for this airgun.
- **NEVER** reuse ammunition.
- **ALWAYS** store the airgun with the safety ON “SAFE” , unloaded, uncocked, separated from the ammunition, out of the reach of children, and in a secure location to prevent unauthorized people from accessing it.
- **DO NOT** attempt to disassemble or tamper with the airgun.
- **DO NOT** put the airgun away loaded. **It is, however recommended that you store your airgun with at least 1,000 psi of high-pressure air.**
- **ALWAYS** store this airgun in a safe location.
- **ALWAYS** store ammunition separately from the gun.
- **NEVER** leave the airgun loaded if it is out of your reach.
- **ALWAYS** unload the airgun before giving it to someone else.
- **ALWAYS** read and follow the manufacturer’s manual and instructions.
- **NEVER** let a person who has not completely read this manual use this product.

## 2. Learning the Parts of the PCP Airgun

Learning the names of the parts of your new PCP Airgun will help you to understand the instruction manual.

Figure 1 – Air Rifle

1. Barrel
2. Muzzle
3. Forend
4. Receiver
5. Stock
6. Cheekpiece
7. Buttpad
8. Trigger
9. Trigger Guard
10. Bolt or Sidelever
11. Breech
12. Quick-Fill

Figure 1

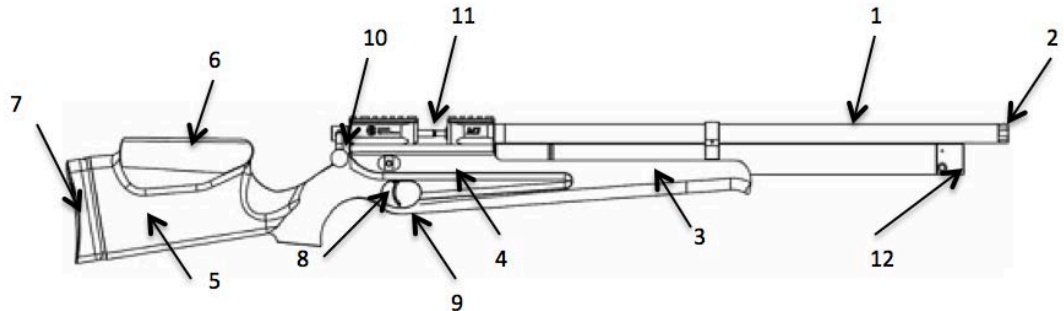

## 3. Operating the Safety

**! WARNING:** BE SURE THE AIRGUN IS ALWAYS POINTED IN A SAFE DIRECTION. NEVER POINT THE AIRGUN AT ANYONE EVEN IF IT IS UNLOADED. ALWAYS ASSUME AND HANDLE THE AIRGUN AS IF IT WERE LOADED AND READY TO FIRE.

**NOTE:** ALWAYS think about safety first. Take your time. If you are uncertain how to proceed, stop and contact Air Venturi for assistance! **Air Venturi service line: 216-220-1180**

**TIP:** To become familiar with the safety, practice putting it on and off several times while the gun is unloaded.

### 3.1 Put the Airgun ON "SAFE"

- ALWAYS point the airgun in a safe direction.
- Locate the cross-bolt safety on the **LEFT** side of the gun, directly behind the trigger as shown in Figure 2.
  - The cross-bolt safety is marked with a **red ring** on the left side of the gun and a **green ring** on the right side.
- Push the bolt completely to the **RIGHT** so the red ring **IS NOT** visible. The gun is now ON "SAFE."
- The safety **IS NOT** ON "SAFE" if the red ring is visible.

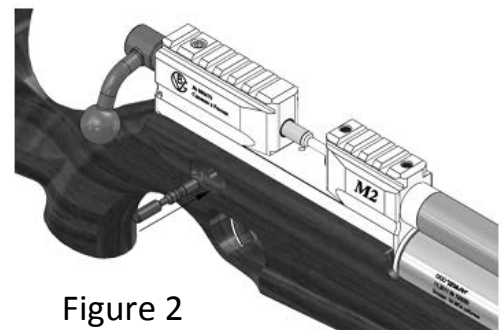

Figure 2

**NOTE:** If the rifle is double-loaded by mistake, remove the magazine from the rifle, close the bolt, point the rifle at a safe target, and when safe to do so, fire the rifle to remove the pellet.

When not in use, the rifle should be unloaded and uncocked. Remove the magazine and leave the lever closed and uncocked when not in use.

To prevent unauthorized use, store the magazine and pellets separate from the air rifle.

**CAUTION:** LIKE ALL MECHANICAL DEVICES, AN AIRGUN SAFETY CAN FAIL. EVEN WHEN THE SAFETY IS ON "SAFE", YOU SHOULD CONTINUE TO HANDLE THE AIRGUN SAFELY. NEVER POINT THE AIRGUN AT ANY PERSON. NEVER POINT THE AIRGUN AT ANYTHING YOU DO NOT INTEND TO SHOOT.

### 3.2 Take the Airgun OFF "SAFE"

- ALWAYS point the airgun in a safe direction.
- Locate the cross-bolt safety on the **RIGHT** side of the gun, directly behind the trigger as shown in Figure 2.
  - The cross-bolt safety is marked with a **red ring** on the left side of the gun and a **green ring** on the right side.
- Push the bolt completely to the **LEFT** so the red ring **IS** visible. The gun is now OFF "SAFE" and ready to fire.
- The airgun is OFF "SAFE" and ready to fire when the red ring **IS** visible.

**NOTE:** The 2-stage trigger is adjustable.

**! WARNING:** KEEP THE AIRGUN ON SAFE UNTIL YOU ARE READY TO SHOOT, THEN PUSH THE SAFETY OFF.

## 4. Fill/Charge Airgun with Hand Pump

**! WARNING:** FILL YOUR PCP AIRGUN USING COMPRESSED AIR OR NITROGEN GAS ONLY. USE OF OTHER GASES, INCLUDING OXYGEN, CAN CAUSE A FIRE OR EXPLOSION THAT MAY RESULT IN PROPERTY DAMAGE, SERIOUS INJURY OR DEATH.

**! WARNING:** DO NOT FILL AIRGUN WITH OXYGEN OR ANY GAS OTHER THAN COMPRESSED AIR OR NITROGEN GAS! FILLING WITH ANYTHING OTHER THAN AIR IS DANGEROUS AND WILL VOID YOUR WARRANTY.

**! WARNING:** DO NOT EXCEED MAXIMUM FILL PRESSURE OF 300 bar/4,350 psi AT ROOM TEMPERATURE!

**NOTE:** To ensure safe operation, avoid distractions such as children or animals when refilling your rifle. Be sure the rifle is unloaded before filling. Wear safety glasses and hearing protection when filling with high-pressure air.

**CAUTION:** NEVER FILL YOUR AIRGUN OVER 300 BAR/4,350 PSI. THIS IS DANGEROUS AND WILL VOID THE WARRANTY. In an over-filled condition (above 300 bar/4,350 psi), the regulator may malfunction and cause the rifle to fire at a much lower velocity.

**NOTE:** When filling the airgun for the FIRST TIME, you must cock the rifle before filling it if the gun was shipped unpressurized.

- 4.1 Locate the male receptor port at the end of the air reservoir tube below the barrel as shown in Figure 3.
- 4.2 Lay the airgun next to the hand pump, making sure the airgun is pointed in a SAFE DIRECTION.
  - The pump should be within easy reach of the male receptor port of the airgun.
- 4.3 Hand-tighten the bleeder valve on the base of the hand pump.
- 4.4 Carefully insert the pump adaptor from the hand pump hose into the airgun's exposed male receptor port.
- 4.5 Put 12 pump strokes into the airgun. This should prime the pump hose enough so you can take an initial reading of the airgun's current pressure level from the integrated pressure gauge (manometer).
  - If you hear air leaking, carefully check all connections. If you cannot resolve the air leaks, contact the retailer that sold you the pump for troubleshooting assistance.
- 4.6 Begin pumping in 20 stroke sets, taking a reading each time of the pressure level on the manometer, and allowing at least a 2-minute cooling period between each set, especially when the pressure reaches 172 bar/2,500 psi.
  - DO NOT exceed 300 bar/4,350 psi.
  - The best technique to operate the pump is to use your upper body weight to push down on the pump, keeping your arms rigid. This method is less fatiguing than using only the strength of your arms to push the pump handle.
- 4.7 Once your rifle has reached the desired pressure, open the bleeder valve on the base of the pump.
  - You will hear a loud rush of air (and maybe see some water vapor) escape from the small hole in the base of the pump.
  - You may now safely remove the pump's probe adapter from the rifle's receptor port.

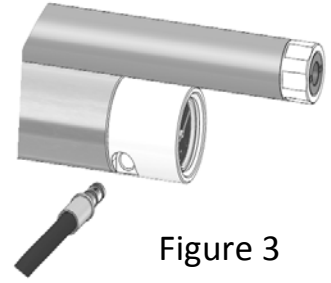

**CAUTION:** Disconnecting the fill hose from the airgun without first bleeding the air may result in injury from hose whip as a result of pressure in the fill hose.

## 5. Fill/Charge Airgun with High Pressure Charging Tank

<b>! WARNING:</b>	<b>FILL YOUR PCP AIRGUN USING COMPRESSED AIR OR NITROGEN GAS ONLY. USE OF OTHER GASES, INCLUDING OXYGEN, CAN CAUSE A FIRE OR EXPLOSION THAT MAY RESULT IN PROPERTY DAMAGE, SERIOUS INJURY OR DEATH.</b>
<b>! WARNING:</b>	<b>DO NOT FILL AIRGUN WITH OXYGEN OR ANY GAS OTHER THAN COMPRESSED AIR OR NITROGEN GAS! FILLING WITH ANYTHING OTHER THAN AIR IS DANGEROUS AND WILL VOID YOUR WARRANTY.</b>
<b>! WARNING:</b>	<b>DO NOT EXCEED MAXIMUM FILL PRESSURE OF 300 bar/4,350 psi AT ROOM TEMPERATURE!</b>
<b>! WARNING:</b>	<b>DISCONNECTING THE FILL HOSE FROM THE AIRGUN WITHOUT FIRST BLEEDING THE AIR MAY RESULT IN INJURY FROM HOSE WHIP DUE TO PRESSURE IN THE FILL HOSE.</b>

**NOTE:** To ensure safe operation, avoid distractions such as children or animals when refilling your rifle. Be sure the rifle is unloaded before filling. Wear safety glasses and hearing protection when filling with high-pressure air.

**CAUTION:** NEVER FILL YOUR AIRGUN OVER 300 BAR/4,350 PSI. THIS IS DANGEROUS AND WILL VOID THE WARRANTY. In an over-filled condition (above 300 bar/4,350 psi), the regulator may malfunction and cause the rifle to fire at a much lower velocity.

**CAUTION:** DO NOT TRY TO REPAIR THE AIRGUN OR TO DISASSEMBLE IT TO CORRECT AN OVERVILL OR VALVE LOCK.

**NOTE:** When filling the airgun for the FIRST TIME, you must check the pressure gauge (manometer). If the gun is not pressurized, you must cock the rifle before filling it.

- 5.1 Locate the male receptor port at the end of the air reservoir tube below the barrel, shown in Figure 3.
- 5.2 Lay the airgun next to the charging tank, making sure the airgun is pointed in a SAFE DIRECTION.
  - The tank or charging station should be within easy reach of the male receptor port of the airgun.
- 5.3 Hand-tighten the bleeder valve on the hose.
- 5.4 Carefully insert the pump adaptor from the tank or charging system hose into the airgun's exposed male receptor port.
- 5.5 Open the main valve of the scuba tank or PCP charging station to allow a SLOW, CONTROLLED infusion of air.
  - If you hear air leaking, carefully check all connections. If you cannot resolve the air leaks, return the hose adaptor unit to your dealer for inspection.
- 5.6 Continue by watching the pressure level on the manometer, especially when the pressure reaches 172 bar/2,500 psi.
  - DO NOT exceed 300 bar/4,350 psi.
- 5.7 Once your rifle has reached the desired pressure, close the main valve on the scuba tank or PCP charging station.
  - DO NOT exceed 300 bar/4,350 psi.
- 5.8 Open the bleed valve.
  - You will hear a loud rush of air (and maybe see some water vapor) escape from the bleed valve.
  - You may now safely remove the pump hose's probe adapter from the rifle's receptor port.

## 6. Uncocking

### 6.1 Uncocking the Airgun

- With the airgun pointed in a SAFE DIRECTION, draw the sidelever rearward – slightly past its stopping point so that you feel some resistance.
- Remove the magazine from the rifle.
- Still holding the side lever securely, pull the trigger.
  - You will feel the side lever pull in the direction away from the trigger.
- Gently ease the side lever toward the closed position.
- Pull the trigger to confirm the rifle is NOT in firing mode.

**NOTE:** The airgun will NOT be harmed if it is dry-fired.



## 7. Loading the Magazine

**! WARNING:** DO NOT INHALE DUST FROM LEAD PROJECTILES OR PUT THEM IN YOUR MOUTH. WASH HANDS AFTER HANDLING LEAD. LEAD PELLETS CONTAIN LEAD, A CHEMICAL KNOWN TO THE STATE OF CALIFORNIA TO CAUSE CANCER AND BIRTH DEFECTS (OR OTHER REPRODUCTIVE HARM).

**! WARNING:** USE THE CORRECT AMMUNITION SIZE FOR YOUR AIR RIFLE MODEL. NEVER REUSE AMMUNITION. THE USE OF ANY OTHER KIND OF AMMUNITION MAY CAUSE INJURY TO YOU OR DAMAGE TO YOUR RIFLE.

**CAUTION:** ALWAYS point the airgun in a SAFE DIRECTION.

**NOTE:** The semi-automatic magazine is designed to ease the process of loading pellets into the rifle. During the process of filling the magazine, its drum rotates clockwise, thus cocking the spring.

- 7.1 To fill the magazine as in Figure 4, press the latch (Figure 4.3) and, while keeping the drum (Figure 4.2) from turning, set it to the end position.
- 7.2 Insert the appropriate caliber pellets into the open chambers on the left and right sides.
- 7.3 Rotate the drum clockwise, filling all the chambers with pellets until the drum stops in the end position.
- 7.4 The magazine is now ready to for installation.

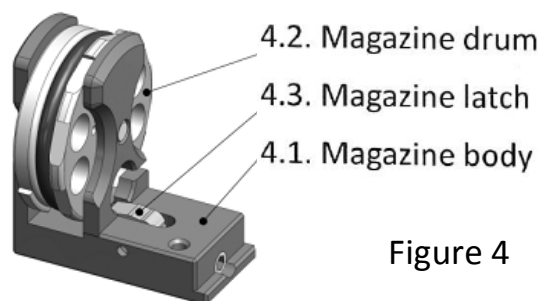

Figure 4

**NOTE:** Do not use deformed or dirty pellets. Do not reuse ammunition. Do not use ammunition that protrudes beyond the drum chambers.

**NOTE:** In order to avoid pellets falling out while being loaded into the magazine drum chambers, it is useful to monitor how tight the seal ring is. If necessary, lubricate the ring; or replace the ring if damaged.

## 8. Installing the Magazine

- 8.1 Open the sidelever and insert the magazine from the left side of the air rifle. Locate it off the receiver slot and the barrel unit extension by moving it to the right all the way in, as in Figure 5.
- 8.2 Close the sidelever pushing a pellet from the drum into the barrel.
- 8.3 Point the rifle in a SAFE direction and take a shot.
- 8.4 During the sidelever opening the drum rotates automatically, revealing the next chambers.
- 8.5 After the last shot, repeat the magazine loading procedures from step 7.

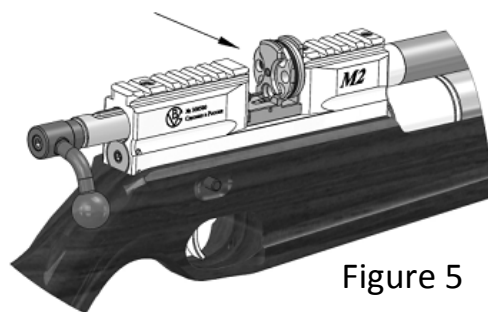

Figure 5



## 9. Firing the Air Rifle

- 9.1 Move the sidelever to the rearmost position.
- 9.2 Insert the magazine or single pellet.
- 9.3 Close the sidelever, (this will load a pellet into the barrel).
- 9.4 Smoothly pull the trigger and shoot.
- 9.5 Repeat steps 9.1 through 9.4 for subsequent shots.
- 9.6 Monitor the gauge pressure in the cylinder. If it is below its operating level, charge the rifle with compressed air.

## 10. Trigger Adjustments

### Lockwork Trigger Adjustment

- 10.1 The trigger pull is adjusted with screw 17. The pull is increased clockwise.
- 10.2 Ending position of the trigger is adjusted with screw 19.
- 10.3 The free play adjustment of the intermediate sear is effected by screw 15, and screw 19 (turned clockwise).
- 10.4 The trigger is adjusted by half-loosening screw 14 and moving the trigger along the base guide 16.

1. Hammer plug
2. Hammer spring bushing
3. Hammer spring
4. Hammer
5. Hammer housing
6. Hammer guide
7. Valve stem
8. Barrel receiver
9. Lockwork spring
10. Sear
11. Secondary sear
12. Safety lock
13. Trigger
14. Trigger screw
15. Trigger creep adjusting screw
16. Trigger base
17. Trigger pull adjustment screw
18. Trigger pull spring
19. Trigger base hold screw

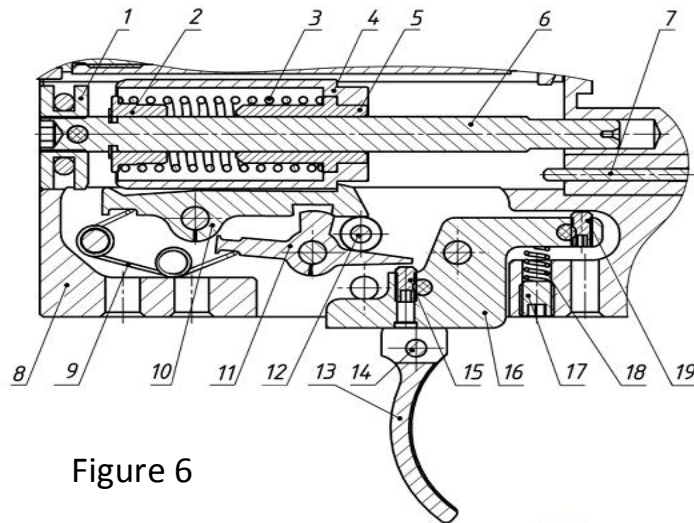

Figure 6

## 11. Cleaning the Barrel

**NOTE:** If your groups are off, it is likely the barrel requires removal and cleaning. BEFORE proceeding, point the airgun in a SAFE DIRECTION.

- 11.1 Put the airgun ON "SAFE" and point the airgun in a SAFE DIRECTION.
- 11.2 DO NOT clean the barrel while the airgun is charged.
  - Completely empty the airgun's reservoir by dry-firing it in a SAFE DIRECTION.

- It is best to clean the air rifle when the air pressure is already so low there is not much air to discharge.

**11.3** Using the Allen key loosen the locking screws (Figure 7.2) in the top of the receiver. This should take 3-4 revolutions.

**11.4** Unscrew the screws (Figure 7.3) that secure the barrel unit in the clamp

**11.5** Having greased the barrel unit in order to ease its sliding in the clamp, carefully remove the barrel unit.

**11.6** Saturate cloth patches with cleaning fluids or lubricants designed for airgun barrels.

**11.7** Push the saturated cloth patch through the muzzle with the cleaning rod until the patch exits at the breech. There's no need to over-clean the barrel.

**11.8** Swab the bore with cloth patches until the last one comes out clean.

- Use only cleaning agents suited for airguns. Never use steel brushes. You may use brass or bronze brushes. Do not use a wooden dowel as a cleaning rod.
- A broken rod in the barrel is extremely difficult to remove.
- It's best to use a coated metal rod designed for cleaning airguns.
- Never shoot cleaning patches from a rifle with a built-in separator, as they may stick during the shooting.

**11.9** Reinstall the barrel unit

- The barrel unit must be installed with the flat part upwards.
- The barrel unit mounts to the receiver, and the clamp screws must be gently tightened

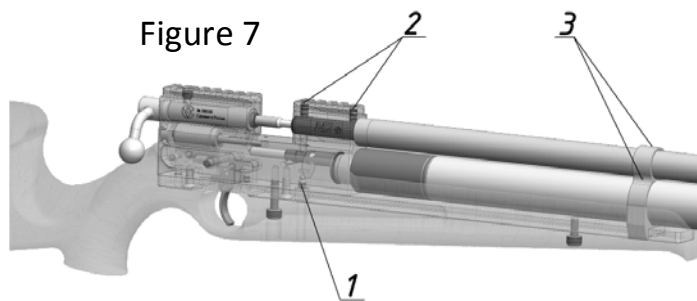

## 12. Operation of Adjustable Stock

**12.1** Folding the rear butt of the adjustable stock (Figure 8)

- Hold the rifle with one hand, and press the button on the butt (Figure 8.1).
- Turn the butt clockwise until it is fixed (Figure 8.2).



Figure 8

**12.2** Unfolding the rear butt of the adjustable stock (Figure 9)

- Hold the rifle with one hand, and raise the butt with the other hand (Figure 9.1).
- Turn the butt counterclockwise until it is fixed (Figure 9.2).



Figure 9

**12.3** To remove the adjustable butt stock (as in Figure 10), remove the screw.



Figure 10

## 13. Storage of the Airgun

- ALWAYS store the airgun with the ammunition removed and the safety on.
- The rifle must be stored and transported only with the hammer de-cocked and without a pellet in the barrel! Carefully check that there is no ammunition in the barrel.
- KEEP THE AIRGUN OUT OF THE REACH OF CHILDREN and users not familiar with its use. Store the airgun separately from the ammunition.
- It is recommended that you store your PCP airgun with at least 1,000 psi of high-pressure air.
- There must not be any oil in the hammer and the hammer chamber. Other metal parts must have a thin layer of grease without any streaks and spots.
- Use silicone lubrication, not oil-based.
- It is possible to store the rifle depressurized, but it may be necessary to disassemble the cylinder and lubricate all the rubber seals before using.
- Use the screw to decompress the rifle before flying an airplane.

## 14. Troubleshooting

TROUBLESHOOTING					
SHOOTING ISSUE	POTENTIAL CAUSE				
	<i>Safety is on</i>	<i>Air Pressure is low</i>	<i>Slide not properly closed &amp; locked</i>	<i>Using incorrect ammunition</i>	<i>Barrel requires cleaning</i>
ACCURACY ISSUES		X		X	X
DOES NOT FIRE	X	X	X		
LOW VELOCITY		X		X	X

# 15. Specifications

Number	Legend	Name	Q-ty	Number	Legend	Name	Q-ty
1	M2R.01.04.01	Valve sleeve	1	24	M2R.01.16.01	Trigger base	1
2	M2R.01.05.01	Valve stem	1		M2R.02.01.01	Extended trigger base	1
3	M2R.01.04.02	Valve	1	25	M2R.01.01.15	Sear	1
4	M2R.01.04.04	Valve spring	1	26	M2R.01.01.16	Secondary sear	1
5	M2R.01.05.02	Valve bushing	1	27	M2R.01.01.07	Lockwork axis	3
6	M2R.01.04.03	Valve plug	1	28	M2R.01.01.13	Lockwork spring	1
7		7*1 O-ring	2	29	M2R.01.01.12	Trigger pull spring	1
8	M2R.01.03.04	Hammer plug	1	30	M2R.01.16.02	Trigger base trigger rod	2
9	M2R.01.03.06	Hammer spring	1	31	M2R.01.01.01	Bolt housing	1
10	M2R.01.03.03	Hammer guide-way	1	32	M2R.01.01.08	Safety lock	1
11	M2R.01.03.07	Hammer	1	33	M2R.01.01.11	Safety lock spring	1
12	M2R.01.03.05	Hammer friction rod	1	34	M2R.01.01.17	Trigger	1
13	M2R.01.03.01	Hammer spring bushing	1	35	M2R.01.01.06	Valve stem guide	1
14	M2R.01.03.02	Hammer housing	1	36	M2R.01.01.05	Receiver cover	1
15		DIN6799 4 washer	1	37	M2R.01.01.02	Trigger valve plug	1
16	M2R.01.02.05	Bolt	1	38		M3*6 DIN 913 screw	2
	M2R.01.02.05-01	Left-hand bolt		39		M5*5 DIN 913 screw	2
17	M2R.01.02.01	Bolt rammer	1	40		M6*6 DIN 913 screw	1
18	M2R.01.02.02	Bolt button	1	41		M8*12 DIN 915 screw	1
19	M2R.01.02.03	Bolt spring	1	42		M3*6 DIN 7984 screw	1
20	M2R.01.02.04	Bolt handle	1	43		3*23,8 needle runner	2
21	M2R.01.04.01	Rammer head	1	44		4*15,8 needle runner	1
22		DIN 912 M5*20 screw	1	45		4*25,8 needle runner	1
23	M2R.01.01.04	Receiver	1	46		4,3 DIN 433 washer	6

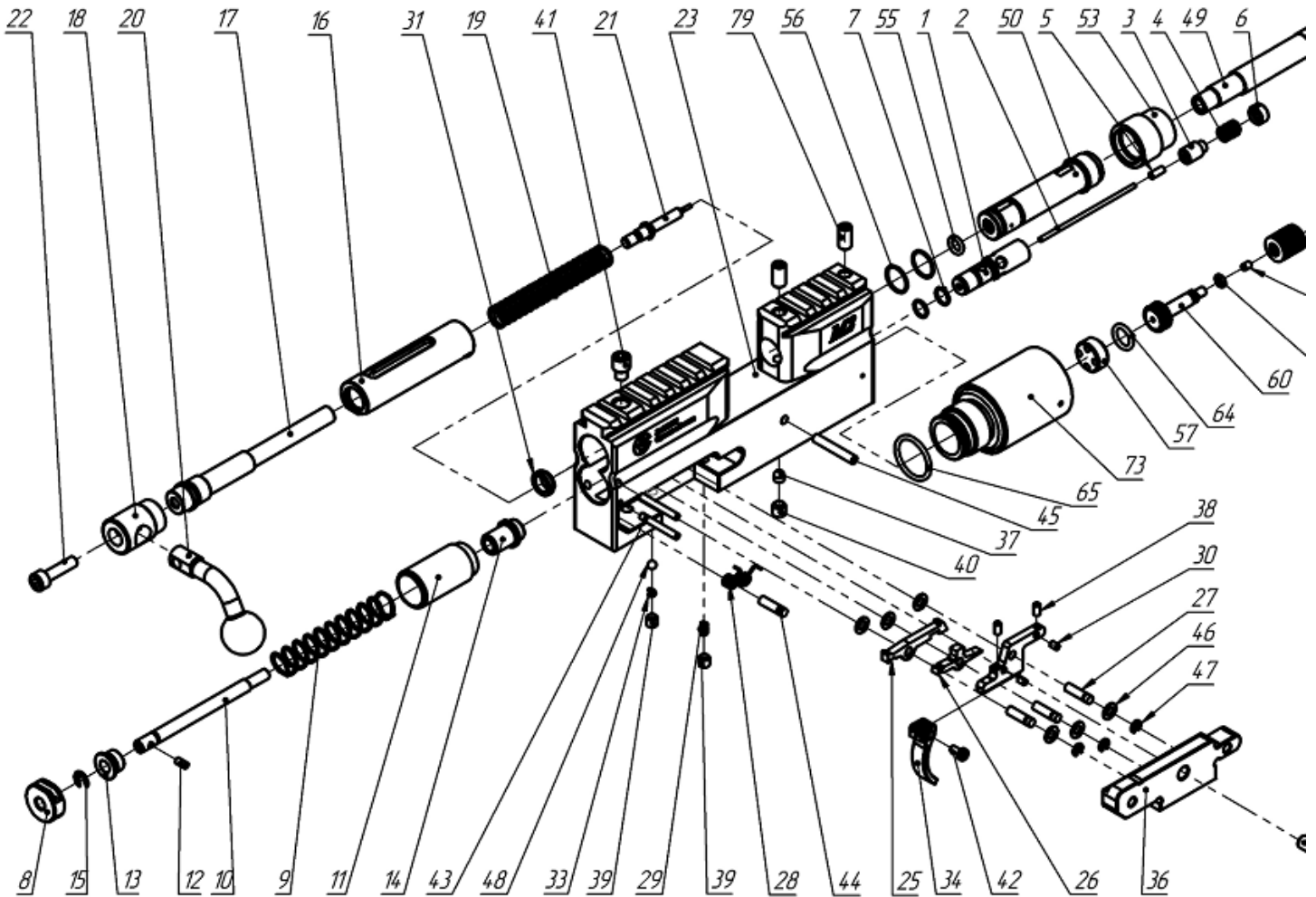

Number	Legend	Name	Q-ty	Number	Legend	Name	Q-ty
47		2 DIN6799 washer	3	63		3.5*1.5 O-ring	3
48		Ball 4 mm	1	64		9*2 O-ring	1
49	M2R.01.06.06	4.5 (.177) / 5.5 (.22) / 6.35 (.25) caliber barrel	1	65		19*2 O-ring	2
	M2R.01.25.01	7.62 (.30) caliber barrel	1	66		12,5*6, 2*0,7 DIN2093B spring	18
	M2R.01.24.01	9 (.35) caliber barrel	1	67		22,2*3 O-Ring	1
50	M2R.01.06.02	Barrel collar (Caliber 4.5 (.177) / 5.5 (.22) / 6.35 (.25))	1	68	M2R.01.11.01	Front plug casing	1
	M2R.01.25.03	Barrel collar (Caliber 7.62 (.30) / 9 (.35))	1	69		M3*6 DIN7991 screw	1
51	M2R.01.06.03	Shroud	1	70		5*1,5 O-Ring	1
	M2R.01.06.03-01	Compact shroud	1	71		Pressure gauge	1
	M2R.01.24.04	Shroud Caliber 9 (.35)	1	72		Cylinder tube	1
52	M2R.01.06.05	Separator 5.5 (.22) / 6.35 (.25)	1	73		Accumulation chamber casing (Cal. 5.5 (.22) / 6.35 (.25) / .62 (.30) / 9 (.35))	1
	M2R.01.12.01	Cutter Caliber 4,5 (.177) / 7.62 (.30) / 9 (.35)	1	74		Clamp	1
53	M2R.01.06.01	Shroud collar	1	75	M2R.01.08.02	22*1 O-Ring	2
	M2R.01.24.02	Shroud collar Caliber 7,62 (.30)	1	76	M2R.01.08.01	35*1,5 O-ring	1
54	M2R.01.06.04	Shroud collar Caliber 9 (.35)	1	77		Rail	1
	M2R.01.06.04-01	4.5 (.177) barrel unit plug	1	78	M2R.01.07.01	M3*4 DIN 913 screw	2
	M2R.01.24.05	5.5 (.22) / 6.35 (.25) barrel unit plug	1	79		M6*12 DIN 913 screw	2
55		9 (.35) barrel plug	1	80		M4*8 DIN 7991 screw	2
		6.35*1.78 ring (Cal. 6.35 (.25))	1	81	M2R.01.00.01	M6*16 DIN 7991 screw	2
		5.7*1.9 ring (Cal. 5.5 (.22))	1	82		Sidelever rammer	1
		4.7*1.42 ring (Cal. 4.5 (.177))	1	83		Sidelever bolt	1
56		8*2 ring (Cal. 7.62 (.30))	2	84		Sidelever lever	2
57	M2R.01.09.01	9*2 ring (Cal. 9 (.35))	1	85		Sidelever lever holder	1
58	M2R.01.09.02	12*1 O-ring	1	86	M2R.01.30.05	Sidelever piston rod	1
59	M2R.01.09.04	Regulator piston plug	1	87	M2R.01.30.04	Sidelever bolt spring	2
60	M2R.01.10.01	Regulator casing	1	88	M2R.01.30.02	1.5*13.8 Needle runner	2
61	M2R.01.10.02	Nozzle screw	1	89	M2R.01.30.01	3*15.8 Needle runner	2
62	M2R.01.09.03	Piston	1	90	M2R.01.30.03	3*8 pin	2
		Seating	1				
		Regulator cover	1				

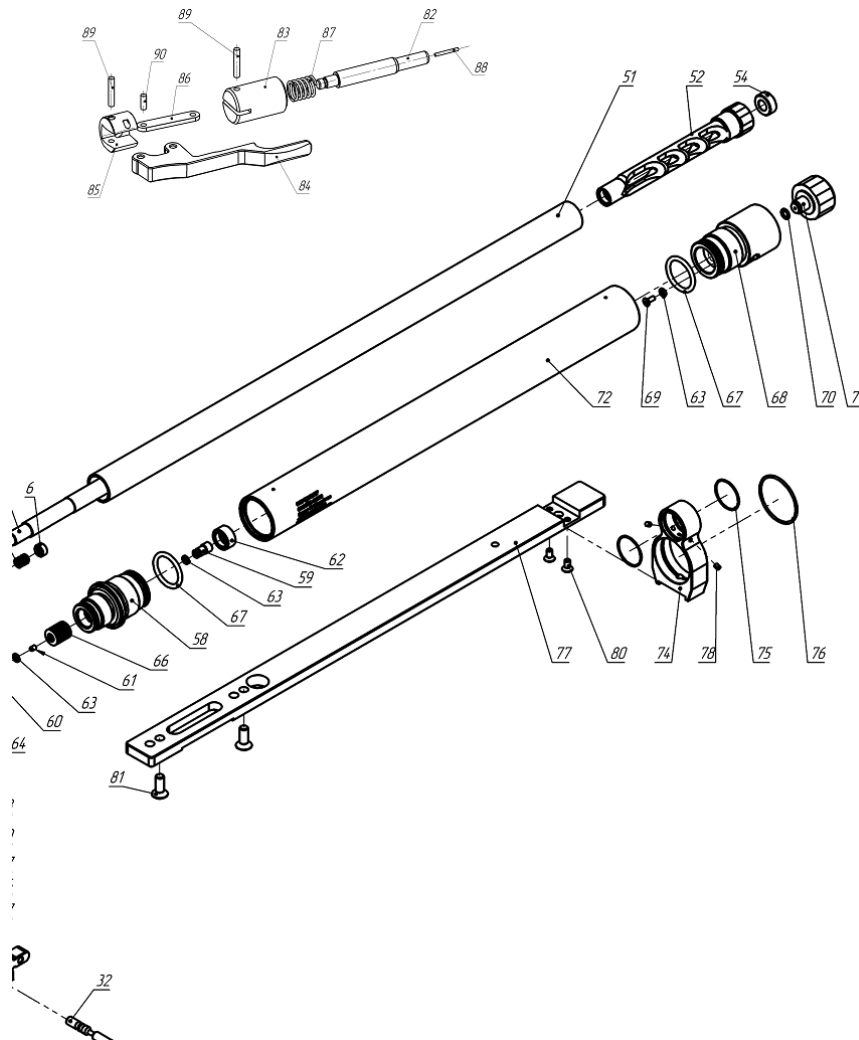

# 16. Warranty

## **One-Year Limited Warranty:**

Your Air Venturi airgun is manufactured to the highest possible standards, using the finest materials to give a lifetime of service. In the unlikely event there are any defects in materials or workmanship in the first twelve (12) months after retail purchase, we will repair or replace the defective items under warranty.

## **What is covered?**

Replacement parts and labor. Transportation charges to consumer for repaired product.

## **What is NOT covered?**

- Any damage or faults caused by owner misuse, action or inaction.
- Transportation charges to Air Venturi for defective products.
- Damages caused by abuse or failure to perform normal maintenance.
- Any other expense.
- Parts subject to normal wear and tear.
- Consequential damages, incidental damages or incidental expenses including damage to property.

This warranty is in addition to your statutory rights. Retain your sales receipt as proof of purchase.

**NOTE:** Some states do not allow the exclusion or limitation of incidental or consequential damages, so the above limitation or exclusion may not apply to you.

## **Warranty claims:**

Warranty claims for U.S. and Canadian customers.

Call Air Venturi at 216-220-1180 before returning any product.

## **Implied warranties:**

Any implied warranties, including the implied warranties of merchantability and fitness for a particular purpose, are limited in duration to one year from date of retail purchase.

**NOTE:** Some states do not allow limitations on how long an implied warranty lasts, so the above limitation may not apply to you.

To the extent any provision of this warranty is prohibited by federal, state or municipal law, which cannot be preempted, it shall not be applicable. This warranty gives you specific legal rights, and you may also have other rights, which vary from state to state and country to country.

Illustrations and photographs are for information purposes only and may not show the exact model you purchased.

## **The warranty shall be invalid if the PCP Airgun:**

- Has been incorrectly disassembled, reassembled or maintained.
- Has been fitted with non-Air Venturi parts.
- Has been abused, misused or improperly stored.
- Original purchase receipt cannot be presented.

## 17. Customer Service

In the unlikely event your rifle malfunctions, DO NOT ATTEMPT TO FIX THE PROBLEM YOURSELF. Please call Air Venturi so we can address any issues or have you return the rifle for repair.

**Air Venturi service line: 216-220-1180**

## 18. Company Contact Information



**Air Venturi  
5135 Naiman Parkway  
Solon, OH 44139  
216-220-1180**

**For assistance, technical support or warranty claims,  
contact the Air Venturi service line: 216-220-1180**