

**IMPORTANT!  
PLEASE READ  
BEFORE FIRING!**

*Supersedes all previous information.*  
PN 8837 Rev. 1/06



# BEEMAN<sup>®</sup> PRECISION AIRGUNS HW77K/HW97K MANUAL

## ⚠ WARNING: ⚠

Do not brandish or display this airgun in public – it may confuse people and may be a crime. Police and others may think this airgun is a firearm. Do not change the coloration and markings to make it look like a firearm. That is dangerous and may be a crime.

## EXTREMELY IMPORTANT:

**DO NOT COCK** your airgun until you have read these cautions and all other printed materials with this airgun. Misuse may void your repair policy, warranty and service contract and may expose you and others to possible harm! A few minutes now will increase the pleasure you will derive from a fine airgun.

## ⚠ WARNING: ⚠

Be sure to read this manual before firing! This airgun is recommended for **ADULT USE ONLY**. Precision adult airguns, because of their design, are a special class of non-powder guns. They may have extremely sensitive trigger mechanisms, very light trigger pulls, may fire if dropped or jarred abruptly, and may not have a trigger block or "safety". This special class of airguns is intended for use by experienced adult shooters who understand their proper and safe use. Airguns are not toys. Careless use may result in serious injury or death. Dangerous within 450 yards (412 meters).

Dealer: This information manual **MUST** be given to retail customers with airgun at time of purchase. Shooters are advised to keep this manual, and associated instructions, for future reference by **ALL** users of this airgun to transfer with the airgun if resold or loaned.

NOTE: All new Beeman® airguns are packed with the following items and you should be very sure that you have received them with your purchase: 1) Trigger tag tied to trigger guard. 2) Statement of Non-liability. 3) Pellets & Pistons Manual -- how to operate your airgun safely and for top performance. 4) Care & Feeding Sheet -- necessary information on maintenance. 5) Inspection Form. 6) Beeman® 5 Year Repair Policy application.

If any of these items are missing, please be sure to obtain them from your dealer immediately before using your airgun. If you need an extra copy of any that are missing, except for the inspection form and repair policy application, Beeman® will be pleased to supply it upon your request at no charge. Request them from Beeman® Precision Airguns, 5454 Argosy Drive, Huntington Beach, Calif. 92649 U.S.A. A self-addressed envelope will expedite their delivery to you. Replacement copies of inspection forms and repair policy applications are not available. They apply to the original sale and can be obtained only at the time of purchase.



**WARNING:** As is common knowledge, **the muzzle end of any airgun is dangerous.**

Perhaps more accidents occur with airguns that are presumed to be unloaded than with ones that are known to be loaded. At all times you must be extremely careful to point a loaded airgun only in a direction in which it is safe to shoot. Never point a airgun towards others or towards any part of your body while cocking or closing it, or after the airgun has been loaded and cocked, **EVEN IF THE SAFETY IS ON! Never depend on any safety.** All safeties are mechanical devices and therefore subject to failure. Many airguns, including airguns, may discharge accidentally, even if the safety is on, when the trigger is pulled partially or when the action is closed. This may be due to excessive lubrication and/or improper or unauthorized adjustments, use of unauthorized parts, impact to the airgun, faulty parts or assembly, etc.

Be sure your airgun is unloaded when crossing a fence, stream, or other barrier; letting go of it for any reason, putting it away, or allowing another person to handle it, entering a house or vehicle, etc. The only sure way of knowing that your airgun is not loaded is to look up the bore or to pass an object all the way through the bore. A projectile or obstruction could be present anywhere in the bore. If your airgun is a barrel-cocking airgun, simply open the barrel slightly and look down the bore from the rear. **YOU MUST BE ABLE TO SEE ALL THE WAY THROUGH THE BORE TO CONSIDER IT CLEAR.** If your airgun has a breech block arrangement that makes it difficult to look down the barrel directly from the rear, you should use a small mirror or pass a flexible or rigid cleaning rod, or similar thin rod of material that will not harm the bore, all the way through the bore to determine if it is clear.

If your airgun does not go off when you expect it to (i.e. when you pull the trigger all or part of the way) assume that the trigger or sear mechanism is hung up. Any airgun can be extremely dangerous in this condition, so open it carefully while being sure that the muzzle is pointed out of harm's way. Safely unload the airgun and do not use it until the unloaded airgun has been carefully checked by a qualified airgunsmith.

You should have a proper cleaning rod both for the above safety checks and to insure best accuracy. A cleaning rod may also be used to clear a projectile or other obstruction out of the barrel. Never fire a projectile to clear a barrel! Such an action will only make the problem worse and may be dangerous. Your airgun should be safely locked up when not in use.

This airgun and its ammunition should be securely stored so that they cannot be handled by children or unauthorized persons.

**TREAT ALL AIRGUNS AS IF LOADED!**

**Basic operation:** Please read the manual “Pellets & Pistons” first. This manual is a supplement to the “Pellets & Pistons” manual – but it must be read also. The “Pellets & Pistons” manual comes with your new airgun and is available from your Beeman® dealer or Beeman®.

**Warning**  
**DO NOT**  
**ADJUST**  
**SCREW 52b**

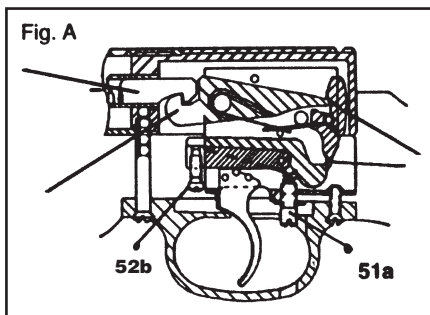

**Trigger adjustments:** The trigger is two stage. The first stage, considered by European shooters as a safety feature, consists of a fairly long slack phase – sometimes mistakenly identified by American shooters as “creep.” The second stage is the actual trigger pull. **The basic adjustment is made by the manufacturer. DO NOT ADJUST! it must be adjusted only by the manufacturer or by a Beeman® Technician. Improper adjustment may cause the airgun to fire when snapped shut.** Fine adjustments can be made simply by inserting a screwdriver through the hole in the trigger guard and turning screw 51a behind the trigger. A counter-clockwise turn, produces a lighter pull. Adjustments below 14oz. pull are not recommended. While a clockwise turn, produces a heavier pull. Excessive lubrication should be kept off the trigger sears. **NOTE:** Please use care when replacing the trigger guard; over-tightening the rear trigger guard screw may make it impossible to release the trigger.

**Cocking the airgun:** Unlatch the cocking lever (under the barrel) by depressing the button at the end of the cocking lever. Firmly pull down the cocking lever as shown in Figure B. Notice the three pinch points while cocking the airgun. You may wish to position your non-cocking hand differently than shown in fig. B. But **BE SURE** you do not allow anything to touch the trigger during cocking. Also, your non-cocking hand should never be near the barrel or loading area (shown as pinch point in Fig. B) until you have cocked the airgun (as evidenced by the safety button popping out and the lack of tension on the cocking lever). Once you have cocked the airgun, return the cocking lever to its storage position under the barrel and re-latch it into place. **CAUTION:** If you do not maintain a firm grip on the cocking lever during the entire time it is down, it could fly out of your hand and cause injury to yourself, a nearby object or person, or damage the airgun itself. Beeman® is not responsible for such damage and such damage is not covered by Beeman® Repair Policies, Service Contracts or Warranty.

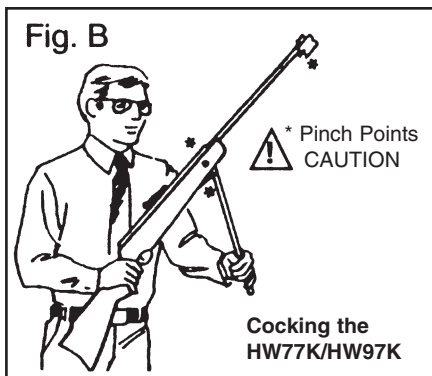

**Safety button:** A “safety” button on the left rear corner of the receiver protrudes automatically when the air rifle is cocked. Push it in to put the airgun in the firing mode. A red indicator button will appear on the right side of the receiver when the airgun is ready to fire. If desired, **the safety may be re-engaged after release**, without firing, by cocking the underlever back down to the full cocked position again. **BE SURE NOT** to touch the safety button during cocking. **NEVER DEPEND** on the “safety” of any airgun! Spring-piston airguns should not be left cocked for long periods. Unload any unattended airgun. A vise or other pressure **MUST NEVER** be applied to the compression tube; that could damage the airgun and interfere with the action of the safety.

The safety of this airgun is designed to function automatically to reduce the possibility of damage to the airgun or persons by the cocking lever during the cocking stroke. It is not the intent of this mechanism to automatically make the airgun safe from firing. Airguns with automatic safeties should never be used to train inexperienced shooters. Shooters should never learn to depend on a safety instead of safe airgun handling procedures.

**Uncocking the airgun;** The HW77K/HW97K cannot be uncocked. The air rifle can only be “released” by simply loading and firing it in a safe direction. Note: never dry-fire a spring-piston airgun. Without a pellet to create a cushion of back pressure, the piston will slam against the chamber wall. Repeated dry firing will damage the piston mechanism. Allowing the cocking lever to slam back into the closed position can cause personal injury as well as damage to the airgun.

Cocking lever linkages should be lubricated with Beeman® MP-5 Metalphilic Oil (9205). The barrel may be cleaned using MP-5 Metalphilic Oil – do not use any nitro solvents suitable for firearms; they will damage breech seals, etc. Beeman® ZIP Clean Kit (9005) contains all the essential airgun maintenance items.

**Accuracy Problems:** Occasional poor accuracy is almost always due to:

- 1. Dirty bore:** Most accuracy complaints are due to a dirty bore. This is especially true of new airguns or those which have been recently lubricated or Super Tuned. This is due to excess lubricant being burned off and/or thrown into the bore of the barrel. Use Beeman® MP-5 which will not attack air seals or stock finish. Clean from the muzzle end with a carefully wiped rod. Use Beeman® Quick Cleaning Pellets between regular cleanings.
- 2. Loose stock screws:** Even one-fourth or a turn can increase group size by as much as three inches at 25 yards. Be sure to tighten all of these screws very well with a proper airgunsmith screwdriver. Excessive vibration of the airgun may loosen these screws; this can be cured by applying a very mild grade of Loc-Tite to the screw threads and/or by eliminating the cause of excessive vibration. Do not over-tighten rear trigger guard screw.
- 3. Over lubrication and lack of break-in:** Serious accuracy testing cannot be carried out with a new spring-piston airgun until it has fired enough times to smooth out the piston action – generally about 500 shots. If the airgun was well lubricated at the beginning of this series of shots, this series will also cause the removal of any excess lubrication. Vertical displacement of shots is usually due to excessive lubrication being burned off by occasional dieseling action, or irregular pellets.

#### Specifications:

**Caliber:** .177/4.5mm, .20/5.0mm

**Barrel:** 12 groove precision rifling for the .177/4.5mm and .20/5mm calibers. Best ordnance steel, precision crowned.

**Stock:** Walnut stained beech, soft rubber buttplate, cut checkering on pistol grip, American Monte Carlo styling with cheekpiece.

**Cocking and Loading:** Underlever cocking. Detent lock for cocking lever. Fully opening breech, direct loading into barrel without mechanical forcing. Smoothing of pellet skirt with Beeman® Pell Seat is easy and recommended for maximum accuracy and power.

**Trigger:** Heavy-duty two-stage match trigger in unitized block. Easily adjustable from manufacturer setting of about 2.5lbs.

**Safety Provision:** Automatic safety to prevent cocking lever snap-up.

**Discharge Sound:** Moderate; below less powerful domestic airguns.

**Firing Behavior:** Recoil about average for spring airguns. Vibration moderate when correctly lubricated.

**Instructions:** Special Beeman® instructions supplied with airgun.

**Pre-Sale Service:** Inspected, test fired.

**Sight Adjustment HW77K:** To adjust point of impact right or left: Turn the adjustable knob located on the side of the rearsight. Rotating the knob clockwise will adjust the point of impact to the left; counterclockwise will adjust the point of impact to the right.

**To adjust elevation:** Turn the adjustable knob located on the top of the rearsight. Moving the knob clockwise will lower the sight; counterclockwise will raise the sight.

**Scope Use:** There are no open sights provided with your HW97K because it has been designed to be used exclusively with a scope. It is very important that the proper scope and scope mounts be selected for optimum performance with this air rifle. Beeman® airgun scopes and scope mounts are highly recommended as they have been designed and manufactured to the finest quality to compliment your HW97K. Consult your dealer for help in selecting the proper scope and scope mounts for your needs.

Beeman® quality airgun scopes are especially recommended for increased accuracy, quick tracking and firing, and extended shooting time into periods of lower illumination (Beeman® scopes enhance low light conditions). NEVER use any telescope sight not specifically manufactured for airgun use. Scopes not designed to withstand the two-way snap of spring piston airguns may cause irreparable damage if used for an extended period of time. Also parallax error on such scopes, even very expensive ones, may increase inaccuracy as much as 300%.

**Special Notes:** Due to the recoil of this air rifle, non-Beeman® scope mounts may begin to slip after extended periods of firing. The best solution for scope movement is to add Beeman® Scope Stop No. 5092 or 5093 (see Beeman® catalog or dealer for the one that is right for your scope). These units simply slip on the scope grooves and are secured into position behind the mounts. Or use Beeman® Scope Mounts 5039, 5030M, 5030H, or 5040 which have an integral recoil stop pin.

**Special Options:** Select condition stock 9904. Super Tune 9910R. Trigger Tune 9919R.

**Recommended Accessories:** Beeman® Super Tuff Case 6448, Belt Pouch 7290, Pell Seat 7199, Deluxe Silent Pellet Trap 4030, Protective Eyewear.

**Recommended Maintenance Items:** Field Cleaning Kit 9005.

**Pellet Recommendations:** Try several types to determine the best for your airgun. We suggest Beeman® Ram Jet, Kodiak, Crow Magnum or FTS.

## CONGRATULATIONS

You have one of the finest adult airguns made.  
Please enjoy it safely for many, many years.

*The Golden Rule of Safe Airgun Handling:*  
**Always see that the airgun is pointed in a safe direction!**  
**Treat all airguns as if loaded!**



**WARNING: MAY FIRE IF DROPPED.** As an adult airgun it is exempt from drop test requirements. It may fire if dropped or hit sharply, even if the safety is in the "ON" position. Do not lean or place your airgun where it may fall, and be careful not to impact any part of a loaded airgun.

## STATEMENT OF NON-LIABILITY

Airguns can cause serious harm, and in some instances, even death and should be handled with great care! This airgun is surrendered by Beeman® Precision Airguns with the express understanding that we assume no liability for its resale, handling, use or possession under local laws or regulations. Neither the manufacturer nor Beeman® Precision Airguns assumes any responsibility whatsoever. Personal injury or property damage resulting from either intentional or accidental discharge or for airgun functions subjected to influences beyond our control, are the sole responsibility of the airgun owner. We will honor no claims that may result from careless handling, unauthorized adjustments, defective or improper ammunition, corrosion or neglect.

By accepting this airgun, the buyer agrees to release the seller and Beeman® Precision Airguns, and all associated persons from liability for any damage to persons or property that may result, for any reason, by using this airgun. **Safety is your responsibility.**



**Beeman® Precision Airguns**, Division of S/R Industries, Inc.  
5454 Argosy Ave., Huntington Beach, CA 92649 USA  
Voice 714/890-4800 Fax 714/890-4808  
Web [www.beeman.com](http://www.beeman.com)